

8" Harmonic Drive Vertical 4th Axis Set HVR-8 series

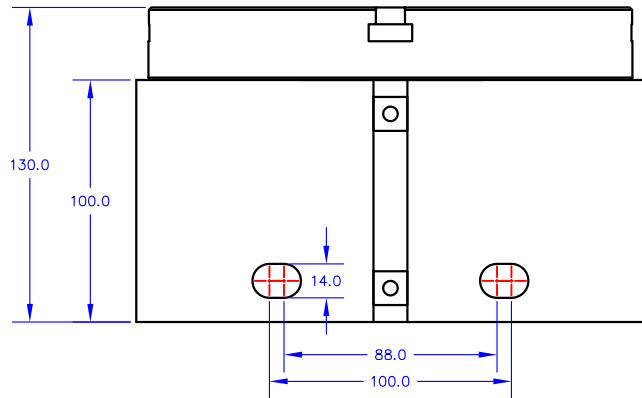

| Mechanical Specifications | |
|-------------------------------|---------------------------|
| Table Diameter: | Ø150mm |
| Center Height: | 100mm |
| Center Bore Diameter: | Ø30.0 |
| Locating Key Width: | 14mm |
| Reduction Ratio: | 100:1 |
| Max Rotate Speed: | 20rpm |
| Backlash: | 0 |
| Repeatable Tolerance: | 3"-0" |
| Max Torque Output: | 100N.m |
| Electric Specifications | |
| Rotary Table Driving: | closed loop stepper motor |
| Home Proximity: | Active Low |
| Accessories Included | |
| Closed Loop Stepper Driver | 1pcs |
| Switch Power Supply | 1pcs |
| Connector Set | 1set |
| Optional Parts | |
| 125mm 3-Jaw Chuck+Adapter Kit | |
| 100mm Height Tall Stock | |

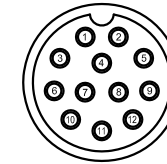

| Signal Connector Pin Definition | | |
|---------------------------------|------|-----------------------|
| Pin | Def. | Remark |
| 1 | HOME | home proximity signal |
| 2 | +12V | home proximity +12V |
| 3 | EVCC | encoder power VCC |
| 4 | EGND | encoder power GND |
| | +COM | +HOME proximity COM |
| 5 | EA+ | encoder A+ pulse |
| 6 | EA- | encoder A- pulse |
| 7 | EB+ | encoder B+ pulse |
| 8 | EB- | encoder B- pulse |
| 9 | A+ | motor phase A+ |
| 10 | A- | motor phase A- |
| 11 | B+ | motor phase B+ |
| 12 | B- | motor phase B- |

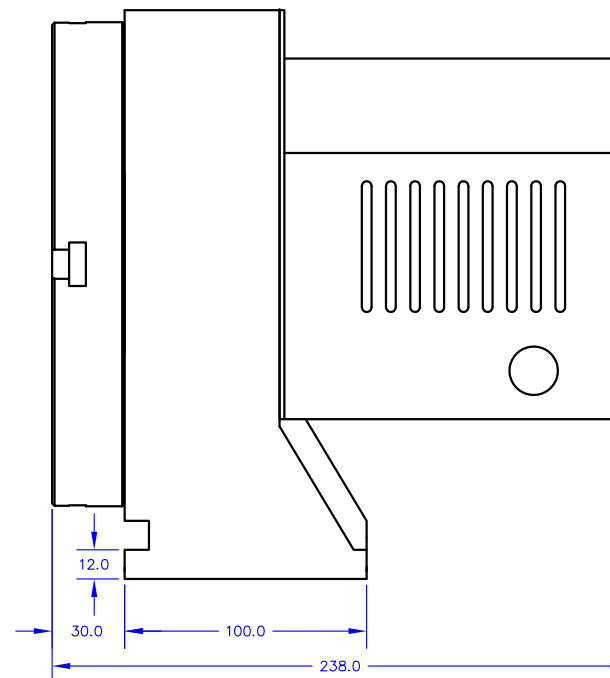
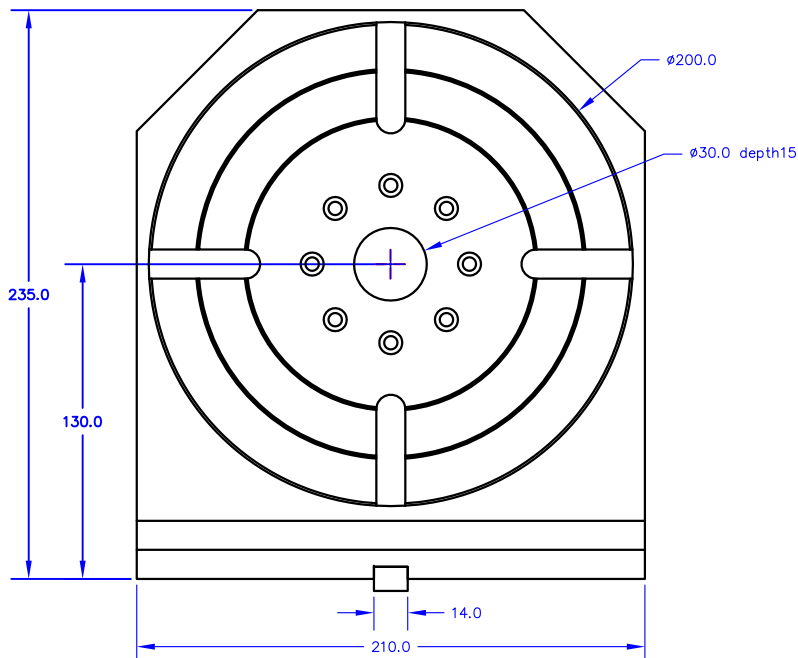

Key Features

- Super high accurate HARMONIC driving with ZERO backlash
- High rotation accuracy with precision crossed roller bearing system
- Strong cast iron body and steel rotary table
- Full sealed inner structure to prevent coolant and chips get inside
- Maintainless and long life design
- Closed loop stepper driving with encoder feedback
- Homing proximity integrated